



Tred-MOR[®]
LEGACY Series

**For Broadloom
Commercial
Double-Stick**

Tred-MOR[®] **1562**

Tred-MOR[®] **2568**

Tred-MOR[®] **2580**

Tred-MOR[®] **2500**

Tred-MOR[®] **3700**

LEGACY™ Series



Tred-MOR®

100% SYNTHETIC RUBBER

- Adds superior cushioning over subfloors for optimum comfort underfoot
- Extends carpet life by up to 50%
- Superior noise suppression
- StainSTOP™ construction restricts spills from seeping to the subfloor

ECO-FRIENDLY

- Contributes to LEED™ flooring system and material building points
- Can be 100% recycled at the end of its useful life
- Contains not less than 20% pre-consumer recycled material

HEALTH AND SAFETY

- Features GUARDIAN™ antimicrobial to inhibit the growth of odor-causing mold, mildew, and bacteria
- Meets or exceeds indoor air quality standards as established by the CRI (Carpet and Rug Institute) Green Label Plus Program
- Hypoallergenic

<p>Tred-MOR® 1562 BV0171</p>	
<p>Tred-MOR® 2568 BV0338</p>	
<p>Tred-MOR® 2580 BV0180</p>	
<p>Tred-MOR® 2500 BV0167</p>	
<p>Tred-MOR® 3700 BV0157</p>	



Comfort

Tred-MOR® carpet cushion has been the premium choice for hospitality and commercial public areas since 1985. With a tensile strength that's perfect for heavy foot and wheeled traffic, these cushions provide the ultimate support – reducing pile-height loss and maintaining a comfortable look and feel.



Noise

Performance and noise control are essential in high-traffic and heavy-use hospitality and commercial environments. Depending on the floor type, noise can easily be transmitted throughout a room or to an area below by simply taking a step. With Tred-MOR, a sound barrier is created on the subfloor that significantly reduces the transfer of impact noise to the room below.

Tred-MOR is made from 100% virgin synthetic rubber and is among the very best materials for use in reducing sound vibration. Made from synthetic rubber and open-cell construction, Tred-MOR naturally dissipates vibration, which helps reduce noise. Since it is a vulcanized rubber, the walls of the cells won't break down and will retain protection from noise for the life of the floor.



Moisture

The Tred-MOR Legacy series features products that are breathable moisture barriers. This means they are 100% resistant to liquids soaking through from the top while simultaneously allowing vapor from the slab to permeate up through the floor system and escape into the atmosphere. This ensures there is no buildup of bacteria or mold under the cushion.

These products are all protected by our Guardian® antimicrobial treatment. While this series works to inhibit the growth of mold, mildew, and odor-causing bacteria, it's important to remember that no vapor barrier is capable of stopping 100% of vapor moisture from passing through.

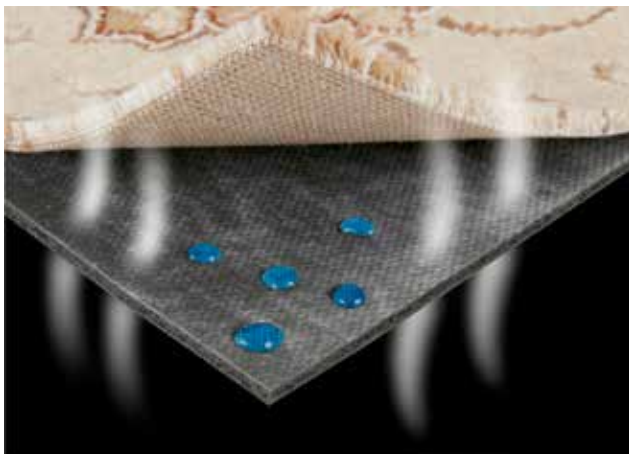

Installation methods











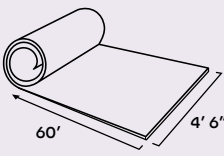
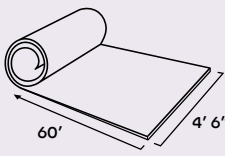
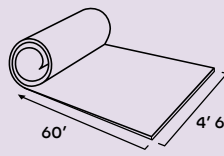
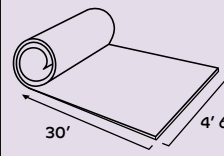
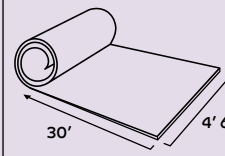



Tred-MOR® 1562

Tred-MOR® 2568

Tred-MOR® 2580

Tred-MOR® 2500

Tred-MOR® 3700

	 BV0171	 BV0338	 BV0180	 BV0167	 BV0157
Commercial Carpet	 	 	 	 	 
Quick-Lift®					



Double-Glue



Stretch-In



Available with Quik-LIFT® Backing

Quik-LIFT® Backing System

The Quik-LIFT felt backing holds the cushion tight to the floor, then releases when pulled up. Take-up is faster, disposal and handling are much easier, and floor prep time is cut to a minimum.

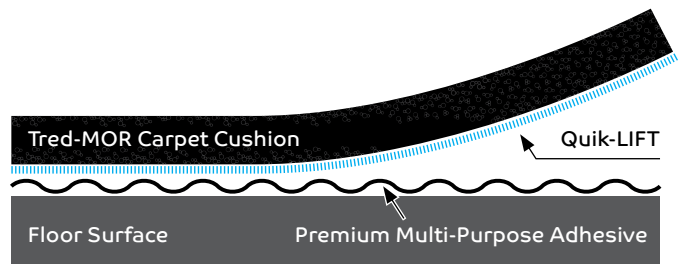

Tred-MOR®

Floor Cushion and Acoustic Systems
by SCI®, a Leggett & Platt company



For more information visit [TredMOR.com](https://www.TredMOR.com)